

## GL7130 Optical Link for 10MHz Reference Signals



### Features & Benefits

- Optimized for transmission of 10MHz Reference Signals
- 10Km Transmission Distance
- Selectable AGC/MGC
- Front Panel Test Port
- Selectable LNB Powering
- Powerful Monitoring Features
- Compatible with all 1<sup>st</sup> Generation Sat-Light Products

### Product Description

Foxcom's Sat-Light/Gold 10MHz Reference Signal Link offers a high performance, cost effective alternative to conventional coaxial-cabled systems. The Gold 10MHz Reference Signal optical link is designed for to meet the needs of a wide range of Satellite and professional VSAT applications. Foxcom's high dynamic range DFB laser delivers exceptional signal quality for the most demanding applications.

The new Gold series is compatible with first generation Sat-Light 7000 Series platform. The Gold Series support L-Band, 70/140MHz IF, Wide Band (10-2200 MHz), 10MHz Reference, Redundancy, M & C, SNMP, Ethernet, and Serial Data Communication.

The link consists of a high dynamic range optical transmitter, which converts incoming 10 MHz reference signals into optics, and an optical receiver that re-converts the optical signal back into RF. Inherently low phase is achieved by direct modulation of the laser diode.

<b>GL7130 RF Optical Link 10MHz Reference Signal, 4dB Optical Budget</b>				
<b>RF Specifications</b>	<b>Units</b>	<b>Typical</b>	<b>Minimum</b>	<b>Maximum</b>
Frequency Range	MHz	10MHz		
Link Gain	dB	Adjustable	-10	+10
Amplitude Response @ Unity Gain 5 - 15 MHz	dB			2.5
Gain Stability	dB/24hr	±0.25		±0.3
SFDR <sup>1</sup>	dB/Hz		100	
CNR <sup>1</sup>	dB	65	60	
Noise Figure (NF) <sup>2</sup>	dB	20		23
Output IP3 (OIP3) <sup>2</sup>	dBm	+30	+20	
Third Order InterModulation [IMD] <sup>4</sup>	dBc		55	40
Group Delay Variation- linear 10-20MHz	ns	5		6
Input Signal Range - Total Power	dBm		-25	+5
Output Signal Range - Total Power	dBm		+15	+10
Maximum Input without Damage	dBm		+15	
Input/Output Impedance	75 or 50			
TX/RX Input/Output return loss 50 Ohm 75 Ohm	dB	-15 -13		-15 -13
RF Connector Type Input/Output Test Port		F, SMA BNC		
Test Port [front panel sample port]	dB	-20	-22	-18

<b>Optical Specifications</b>		<b>Typical</b>	<b>Minimum</b>	<b>Maximum</b>
Optical Power Output	dBm	3	2	4
Optical Budget / Distance 4 dB optical budget	dB/Km	1310 nm   1550 nm 8  15		
Optical Connector Types		FC/APC		
Optical Wavelength	nm	1310/1550/CWDM		

Electrical Specification				
Supply Voltage	Vdc	13	12.7	18
Supply Current [TX] <sup>5</sup>	Amp	0.4		
Supply Current (RX)	Amp	0.3		
Physical Specifications				
Operating Temperature Range			-10	+55
Dimensions [D×W×H]				
MTBF	Hours	TX: 309, 481 RX: 359, 057		

1. -5 dBm RF input, link gain =10dB, IMD=-40 dBc @ 3 dB opt. budget
1. -25 dBm RF input, link gain =20dB, IMD=-40 dBc @ 3 dB opt. budget
2. 0dBm RF Output, IMD=-40dBc
3. User adjustable
4. Under 10°C add 120 mA [laser heating]

## Ordering Information

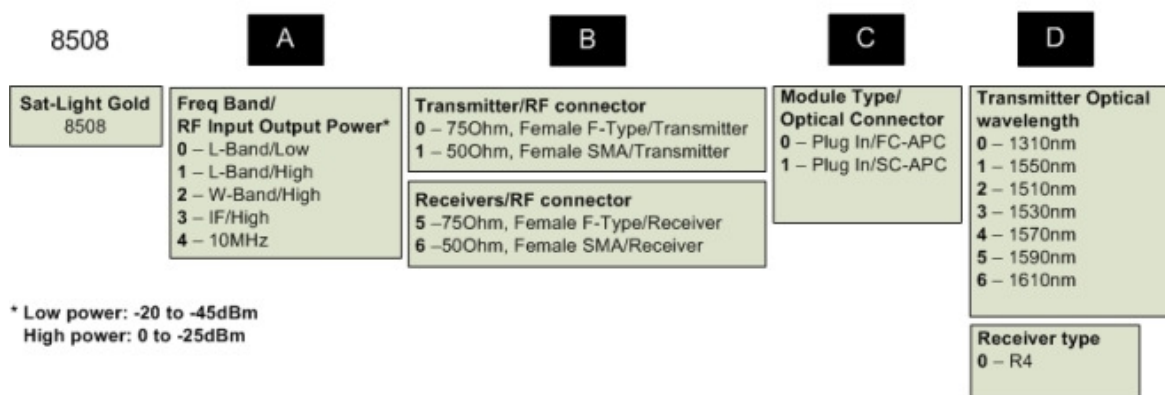

Example: Plug in module, L-band, low RF input, 1310nm laser, F-Type RF connector and FC/APC optical connector

8508 0000